

EAGLE EDGE RETRACTABLE TYPE FALL ARRESTER 6 M

REF.
NEO060

neofeu.com

FALL PROTECTION ONLY*
*Un seul métier, l'antichute

CERTIFICATION : EN 360 : 2002 / REGULATION : 2016 / 425
SHEETS : VG11.060 / VG11.062



R = 0.5

TESTED
140 KG

TESTED FOR
HORIZONTAL
USE

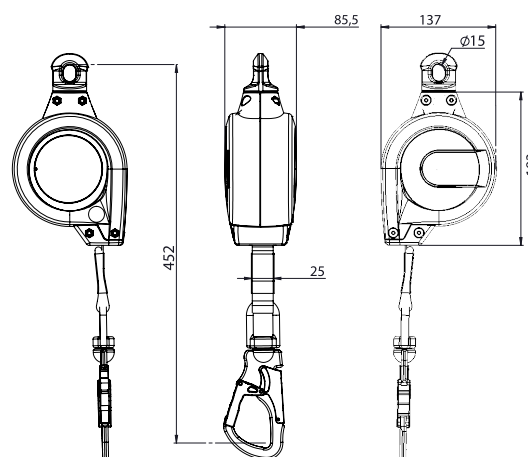

DIMENSIONS (in mm)

TECHNICAL SPECIFICATIONS

- Vertical and horizontal use
- Maxi user weight 140 kg
- Dyneema webbing wide 25 mm (R>22 kN)
- Composite housing PA Polyamid + fiber glass
- Static resistance >15 kN
- Arrest force < 600 daN
- Vertical minimum clearance : 2,6 m
- Horizontal minimum clearance : 4,0 m
- Swivel anchor hook on top fitted with automatic twist lock connector in aluminum, opening 22 mm
- Automatic swivel connector on cable with fall indicator opening 28 mm in anodized aluminum
- Temperature of use : -30°C to +50°C
- Weight : 1,8 kg

DESCRIPTION

The Eagle Edge is a fall arrester equipped with a 6 m webbing line retracting automatically and fitted with 2 pawls braking immediately in case of fall and with an internal energy dissipating element. Lightweight and compact, it is recommended for both vertical and horizontal use for all users weighing up to 140 kg.

USE

Works on height with vertical fall hazards. Works in horizontal with fall hazard over a sharp edge (R = 0,5 mm).